

## OP-S10GXX-40 10G CWDM SFP+ Module, SM 40km LC DDM

### Features

- Optical interface compliant to IEEE802.3ae 10GBase-ER
- Electrical interface compliant with SFF-8431
- CWDM EML laser transmitter
- Up to 40KM transmission on SMF
- Compliant with SFF-8472
- Case operating temperature range 0°C to 70°C
- Duplex LC connector interface
- Built-in digital diagnostic functions
- Low power consumption



### Applications

- 10GBASE-ER/EW
- Other Optical Links

### Description

OP-S10GXX-40 transceiver is designed for CWDM 10G Ethernet serial optical data communication up to 40KM on SMF. It is compliant with Multi-Sourcing Agreement (MSA) SFF-8431 and SFF-8472. There are 18 wavelengths from 1270nm to 1610nm available, with each step 20nm.

### Absolute Maximum Ratings

Parameter	Symbol	Min.	Max.	Unit
Storage Temperature	Ts	-40	85	°C
Supply Voltage	Vcc	-0.5	4	V
Operating Humidity	RH	5	95	%
Power Consumption			1.5	W

### Recommended Operating Conditions

Parameter	Symbol	Min.	Typical	Max.	Unit
Operating Case Temperature	Tc	0		70	°C
Power Supply Voltage	Vcc	3.15	3.3	3.45	V
Power Supply Current	Icc			290	mA
Data Rate	-		10.3125		Gbps



## Optical Characteristics

Parameter	Symbol	Min.	Typical	Max.	Unit
<b>Transmitter</b>					
Average Output Power	P <sub>o</sub>	-2		3	dBm
Center Wavelength	$\lambda$	$\lambda_c-6.5$	$\lambda_c$	$\lambda_c+6.5$	nm
Extinction Ratio	E <sub>r</sub>	3.5			dB
Spectral Width(RMS)	$\Delta\lambda$			1	nm
Side Mode Suppression Ratio	SMSR	30			dB
Transmitter and Dispersion Penalty	TDP			3	dB
Average Launch Power OFF Transmitter	P <sub>off</sub>			-30	dBm
Output Optical Eye Mask	Compliant with IEEE 802.3ae				
<b>Receiver</b>					
Receiver Sensitivity	S			-14	dBm
Center Wavelength	$\lambda_c$	1260		1620	nm
Receiver Overload	P <sub>in</sub>	0.5			dBm
LOS De-Assert	LOS <sub>D</sub>			-17	dBm
LOS Assert	LOS <sub>A</sub>	-30			dBm
LOS Hysteresis		1			dB

### Notes:

1. The optical power is launched into SMF
2. ITU-T G.694.2 CWDM Wavelength from 1270nm to 1610nm, each step 20nm
3. Measured with a PRBS 2<sup>31</sup>-1 test pattern @10.3125Gbps
4. Measured with a PRBS 2<sup>31</sup>-1 test pattern @10.3125Gbps, BER ≤ 1x10<sup>-12</sup>

## Electrical Characteristics

Parameter	Symbol	Min.	Typ.	Max.	Unit
<b>Transmitter</b>					
Differential Data Input Swing	V <sub>in</sub>	180		700	mV
Input Differential Impedance	Z <sub>in</sub>		100		Ω
TX_Fault	Normal Operation	0		0.5	V
	Transmitter Fault	2		V <sub>cc</sub>	V
TX_Disable	Laser Enable	0		0.8	V
	Laser Disable	2		V <sub>cc</sub> +0.3	V
<b>Receiver</b>					



Optinet Technology Co., Ltd

Add: 4th Floor Xiufeng Industrial Park, Buji Street, Longgang District, Shenzhen, China 518112

Tel: +86-755-28471034 Fax: +86-755-61824579

www.optinetec.com sales@optinetec.com

Differential Data Output Swing		Vout	300		850	mV
Output Differential Impedance		Zo		100		mV
Rx_LOS	Normal Operation		0		0.5	V
	Loss of Signal		2		Vcc	V

## Digital Diagnostic Function

OP-S10GXX-40 transceiver supports the 2-wire serial communication protocol as defined in SFP MSA. The standard SFP serial ID provides access to identification information that describes the transceiver's capabilities, manufacturer, part no and other information.

Additionally, the digital diagnostic monitoring interface also defines another 256-byte memory map in EEPROM, which makes use of the 8 bit address 1010001X (A2h). It allows real-time access to transceiver's working temperature, laser bias current, transmitted optical power, receiver sensitivity and supply voltage.

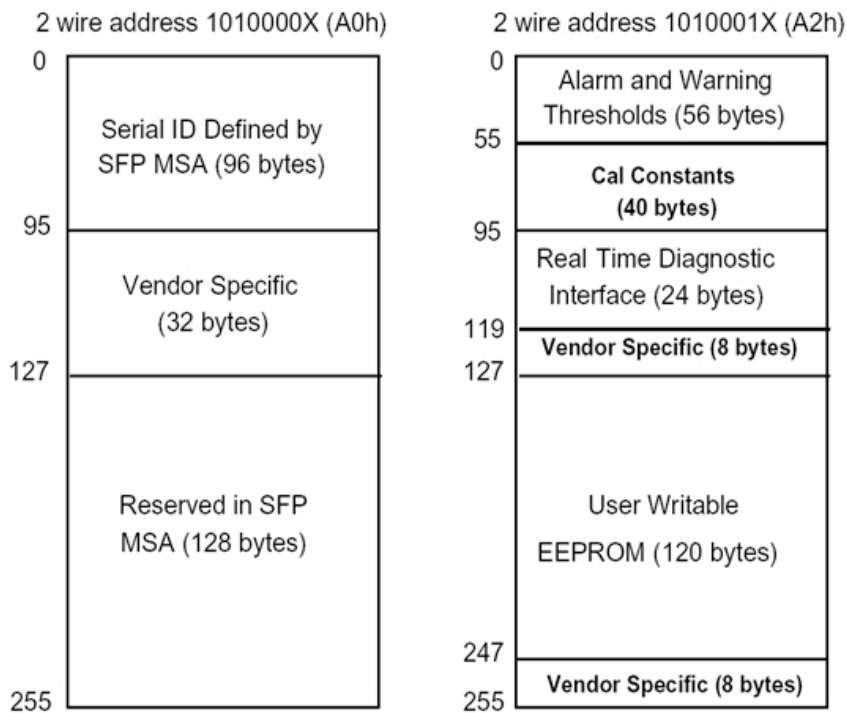

## Pin Definitions

Diagram of Connector Block Pins on Host Board

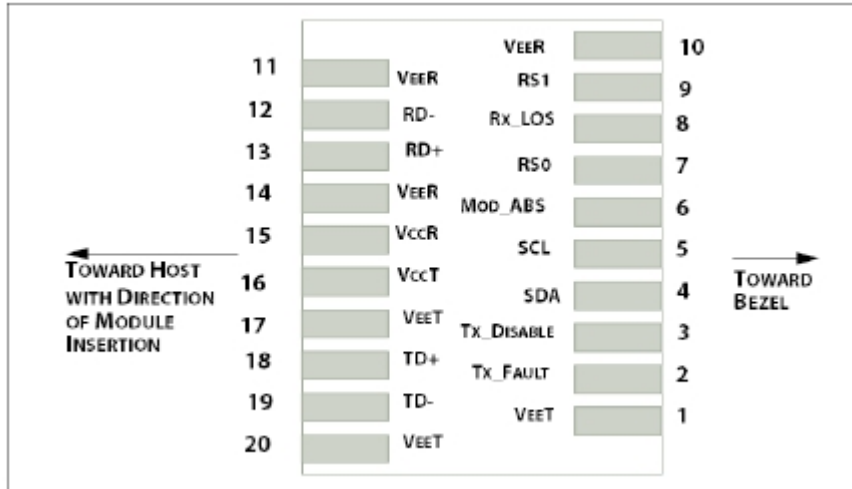

Pin	Symbol	Name/Description
1	VeeT	Transmitter Ground
2	Tx_FAULT	Transmitter Fault
3	Tx_DISABLE	Transmitter Disable. Laser output disabled on high or open
4	SDA	2-wire Serial Interface Data Line
5	SCL	2-wire Serial Interface Clock Line
6	MOD_ABS	Module Absent, connected to VeeT or VeeR in the module
7	RS0	Rate Select 0, not implement
8	RX_LOS	Receiver loss of signal
9	RS1	Rate Select 1, not implement
10	VeeR	Receiver Ground
11	VeeR	Receiver Ground
12	RD-	Receiver Inverted Data Output
13	RD+	Receiver Non-Inverted Data Output
14	VeeR	Receiver Ground
15	VccR	Receiver Power Supply
16	VccT	Transmitter Power Supply
17	VeeT	Transmitter Ground
18	TD+	Transmitter Non-Inverted Data Input
19	TD-	Transmitter Inverted Data Input
20	VeeT	Transmitter Ground

### Notes:

1. The Module ground pins are isolated from the module case
2. The pins should be pulled up with 4.7k – 10kΩ to a voltage between 3.15V and 3.6V on host board
3. The pins is pulled to VccT with 4.7 kΩ to 10kΩ resistor in the module
4. The pins are pulled low to VccT with a > 30 kΩ resistors in the module

## Recommended Host Board Power Supply Unit

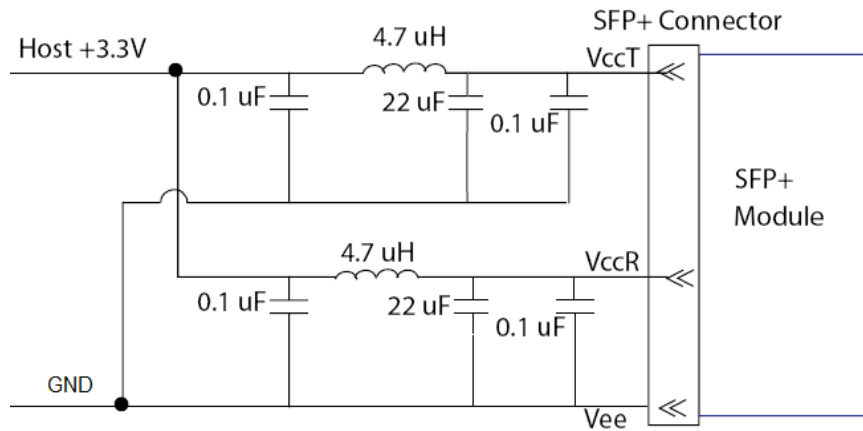

## Recommended Interface Circuit

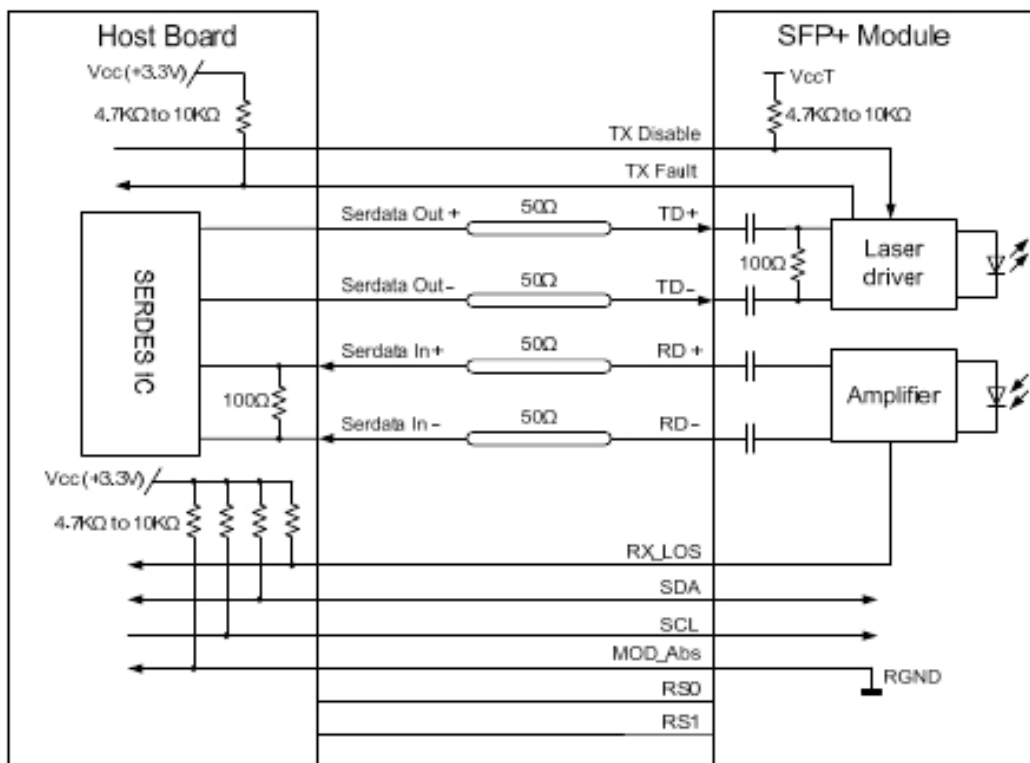

## Mechanical Diagram

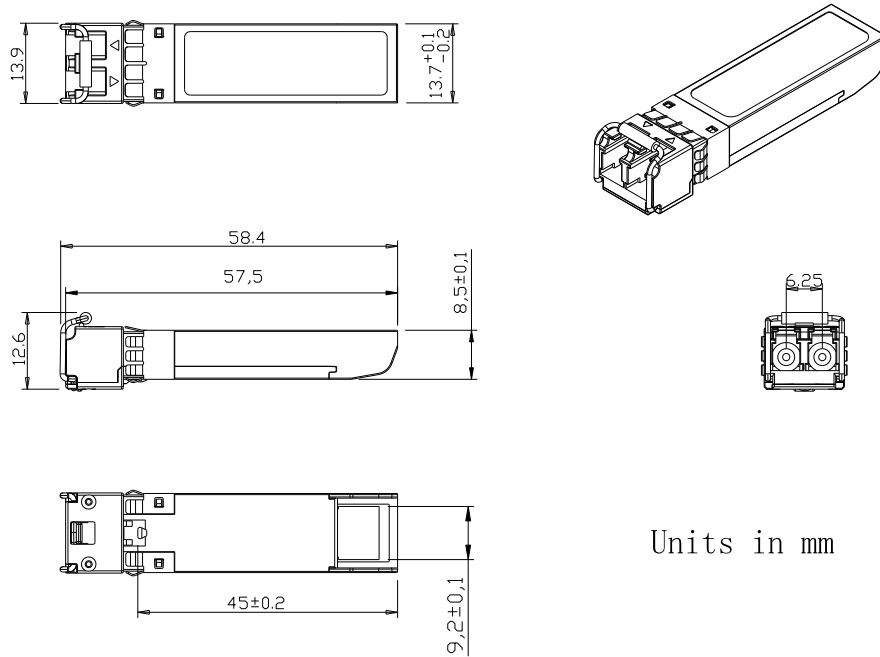

Units in mm

## Ordering Information

### λC Wavelength Guide

Code	λc	Unit	Code	λc	Unit
1	1270	nm	10	1450	nm
2	1290	nm	11	1470	nm
3	1310	nm	12	1490	nm
4	1330	nm	13	1510	nm
5	1350	nm	14	1530	nm
6	1370	nm	15	1550	nm
7	1390	nm	16	1570	nm
8	1410	nm	17	1590	nm
9	1430	nm	18	1610	nm

Part No	Data Rate	Wavelength	Fiber	Reach	Temperature	DDM
OP-S10G27-40	10Gbps	1270nm	SMF	40KM	0~70°C	YES
OP-S10G29-40	10Gbps	1290nm	SMF	40KM	0~70°C	YES
OP-S10G31-40	10Gbps	1310nm	SMF	40KM	0~70°C	YES
OP-S10G33-40	10Gbps	1330nm	SMF	40KM	0~70°C	YES
OP-S10G35-40	10Gbps	1350nm	SMF	40KM	0~70°C	YES
OP-S10G37-40	10Gbps	1370nm	SMF	40KM	0~70°C	YES
OP-S10G39-40	10Gbps	1390nm	SMF	40KM	0~70°C	YES

**Optinet Technology Co., Ltd**

Add: 4th Floor Xiufeng Industrial Park, Buji Street, Longgang District, Shenzhen, China 518112

Tel: +86-755-28471034 Fax: +86-755-61824579

www.optinetec.com sales@optinetec.com

OP-S10G47-40	10Gbps	1470nm	SMF	40KM	0~70°C	YES
OP-S10G49-40	10Gbps	1490nm	SMF	40KM	0~70°C	YES
OP-S10G51-40	10Gbps	1510nm	SMF	40KM	0~70°C	YES
OP-S10G53-40	10Gbps	1530nm	SMF	40KM	0~70°C	YES
OP-S10G55-40	10Gbps	1550nm	SMF	40KM	0~70°C	YES
OP-S10G57-40	10Gbps	1570nm	SMF	40KM	0~70°C	YES
OP-S10G59-40	10Gbps	1590nm	SMF	40KM	0~70°C	YES
OP-S10G61-40	10Gbps	1610nm	SMF	40KM	0~70°C	YES

**Warnings**

Handling Precautions: This device is susceptible to damage as a result of electrostatic discharge(ESD). A static free environment is highly recommended. Follow guidelines according to proper ESD procedures.

Laser Safety: Radiation emitted by laser devices can be dangerous to human eyes. Avoid eye exposure to direct or indirect radiation.